



Overview of Smart Grid Technology as a Renewable Energy Source

Tochi Andrew Owunna ^{a#} and Emmanuel Ifeanyi Obeagu ^{b*}

^a Babcock University Teaching Hospital Ilishan Remo Ogun State, Nigeria.

^b Department of Medical Laboratory Science, Kampala International University, Western Campus, Ishaka, Uganda.

Authors' contributions

This work was carried out in collaboration between both authors. Both authors read and approved the final manuscript.

Article Information

DOI: 10.9734/JENRR/2022/v12i3239

Open Peer Review History:

This journal follows the Advanced Open Peer Review policy. Identity of the Reviewers, Editor(s) and additional Reviewers, peer review comments, different versions of the manuscript, comments of the editors, etc are available here: <https://www.sdiarticle5.com/review-history/92525>

Review Article

Received 17 August 2022
Accepted 05 October 2022
Published 08 October 2022

ABSTRACT

A smart grid is an electricity system that uses digital communications technology to detect, respond to, and take appropriate action in response to changes in demand and a variety of other problems. The secret to effective utilization of distributed energy resources is smart grid technology. Opportunities for renewable energy systems to address electricity generation appear to be growing, especially in light of the importance of climate change, the rising cost of petroleum products, and the falling cost of renewable energy power systems. However, an effective energy management strategy of system must be addressed in order to achieve commercialization and widespread use. Electric power networks have recently benefited from the effective application of the smart grid idea. This research work examines the overview of smart grid technology as a renewable energy source. The concept of a smart grid as well as the advantages and disadvantages of a smart grid renewable energy. The success of promoting renewable energy is significantly influenced by pricing. As a result, it is crucial to evaluate the distinctive qualities connected with alternative sources of renewable energy in order to get insight into the pricing of renewable energy. A survey of recent work in renewable smart grid systems shows the exciting future potential of such research traits. Both policymakers and those who create and use renewable energy systems would benefit from this.

Keywords: Smart grid; technology; renewable; energy source.

Maintenance;

*Corresponding author: E-mail: emmanuelobeagu@yahoo.com;

1. INTRODUCTION

The production of electricity is carried out by several types of power plants. Despite the fact that power plants can be categorized in a number of ways, we will only use one term in this study due to the congress's focus on it. Sources of renewable energy (RESs) and sources of non-renewable energy (NESs). Traditional power sources include NESs. They are no longer useful. They cause a number of environmental issues, including air pollution. On earth, conventional power sources are also scarce. The term "RESs" refers to power generation techniques that are more environmentally friendly, plentiful, and free of pollution. Solar, wind, hydropower, biomass, hydrogen, and geothermal energy are examples of RESs [1].

"Many nations have proposed the development of smart grids in recent years in an effort to address the distributed energy grid connection problem and create a more secure, dependable, cost-effective, and environmentally friendly power system in the face of increasing pressure on resources and the environment. Power generation, transmission, substations, power distribution, electricity, scheduling, and information of all aspects of power systems are all covered by the smart grid, which employs many new technologies to achieve a high degree of integration and unity of power flow, information flow, and business flow" [2].

The output of renewable energy is rising as a result of several factors. There are steps being taken to reduce pollution from the use of fossil fuels in the production of electricity, including efforts to minimize greenhouse gas emissions, as well as regulatory and policy obligations and incentives. Although not all renewable energy sources are variable, wind and solar photovoltaics (PV) presently account for the majority of the rise in the production of renewable electricity, and their production aims to exploit the freely available but changeable amounts of wind and solar irradiance [3].

Renewable energy sources are sometimes referred to as alternative kinds of energy. Any energy source that may be naturally renewed at a pace comparable to or faster than that resource's rate of energy consumption is referred to as a renewable energy source. Another definition of a renewable energy source is a durable resource that is readily available in nature (van Vliet, 2012). Although energy conversion processes sometimes lose their

quantities due to the use of renewable energy sources, these resources may always be replenished or compensated (Labudovi and Barbir, 2002). According to Strielkowski *et al.* (2013), the renewable energy sources, which will be discussed in this paper, can support independence, employment, and inherently enhance the environment.

It is important to note that most studies analyze each renewable energy source separately, excluding them from consideration as a group. To the best of the authors' knowledge, there hasn't been much research done on renewable energy sources, their benefits, and drawbacks. As a result, this research aims to add to the body of knowledge already in existence and advance our understanding of the features of renewable energy sources [4].

2. SMART GRID TECHNOLOGY

The idea of a "smart Grid" integrates a multitude of technologies, end-user options, and policy and regulatory factors. There isn't a single precise definition of it.

The smart grid is an electricity network that can intelligently integrate the actions of all users connected to it, including generators, consumers, and those who do both, in order to efficiently deliver sustainable, affordable, and secure electricity supplies, according to the European Technology Platform.

"The US Department of Energy states that a smart grid uses digital technology to enhance the economic and energy efficiency (reliability, security, and efficiency) of the electrical system from large generation to consumers' electricity delivery systems and an increasing number of distributed generation and storage resources" [5].

"A smart grid system is necessary because it can protect against cyber security, expand the grid for the seamless integration of renewable energies like wind" [6], "electrical vehicles and battery systems using power electronics, and solar" [7], provide smart metering, enable energy observation and control, reduce fluctuations in voltage, frequency, and current, and improve harmony between the grid and the rest of the power grid [8].

2.1 Basic Structure of the Smart Grid System

Bidirectional power flow and information and communication technology make up a smart grid

system. The grid's electricity equipment is intelligent and communicates with one another. They are devices that can be observed and controlled.

2.2 Evolution of Smart Grid

The current electrical utility system is a result of the world's fast urbanization and infrastructural growth over the past century. Even though they operate in several different geographies, utility firms utilize comparable technology [9]. The construction and growth of the electrical power system are also influenced by political, economic, and geographic considerations. Despite these variations, the basic structure of the current electrical power system has not changed. Since the introduction of the Smart Grid, the power industry has operated with a distinct difference between its generation, transmission, and distribution subsystems. As a result, each phase has influenced distinct levels of automation, transformation, and evolution. According to Fig. 4 below, the current electrical utility grid is a hierarchical structure, with power plants at the top of the chain guaranteeing power delivery to consumers at the bottom. The system is a one-way pipeline, thus the source lacks real-

time knowledge of the service parameters at the termination point. Utility grid is consequently over-engineered in order to handle maximum predicted peak demand over its total load. Peak demand doesn't happen regularly, so a system built around it is ineffective. Additionally, the system's stability has declined as a result of a sharp increase in energy use and scant infrastructure spending. Any irregularity in the distribution network or any unexpected increase in demand that results in component failures might cause catastrophic blackouts when the safe margins are exhausted. Utility companies have created various degrees of control and command functions to make troubleshooting and maintenance of the pricey upstream infrastructure easier [10]. A typical and widely used example is SCADA. A shift toward the Smart Grid must begin at the bottom of the food chain, from the distribution system, where 90% of all disturbances and power outages originate. The need to update the distribution network by introducing new technologies that can aid in revenue protection and DSM has been accelerated by utilities' (utility companies') inability to increase their generation capacity in response to the rising demand for electricity and the rapid increase in the price of fossil fuels.

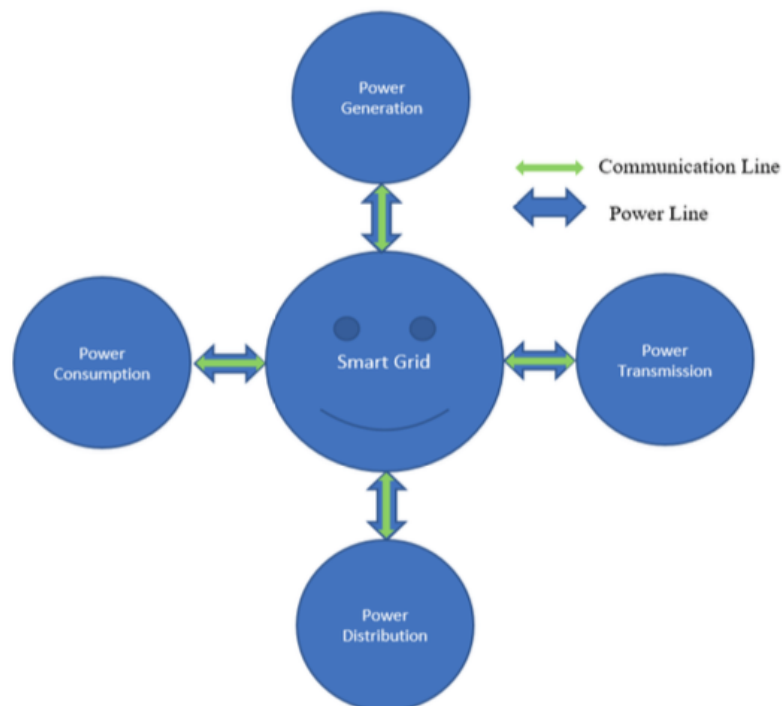

Fig. 1. Basic Structure of the smart grid system

Source from Colak [8]

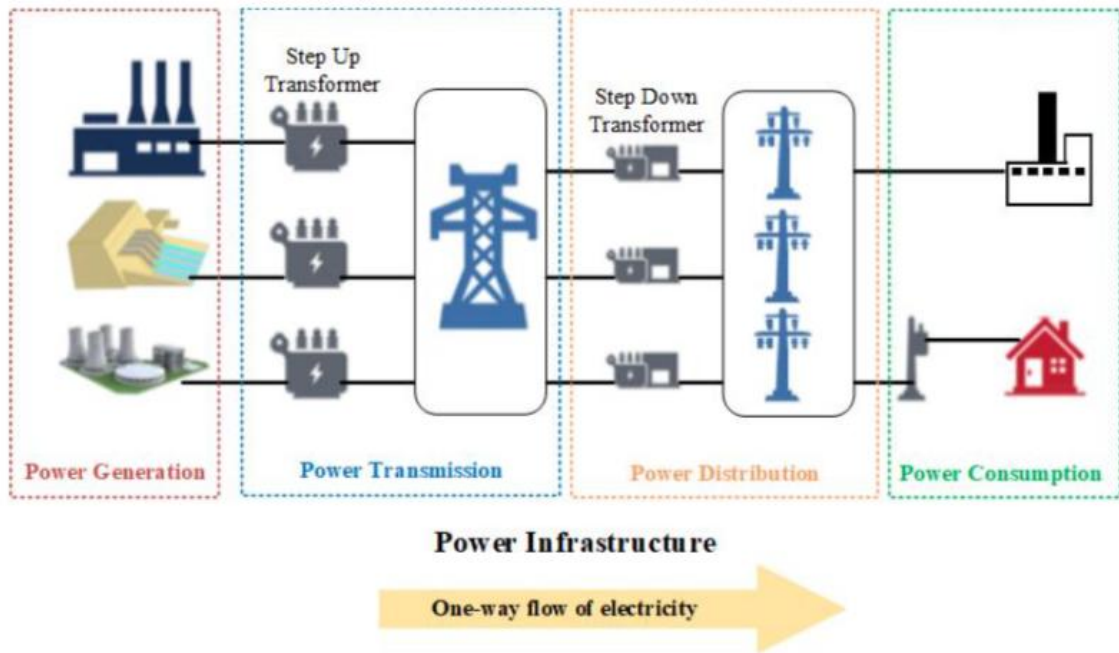

Fig. 2. Structure of classical power grid

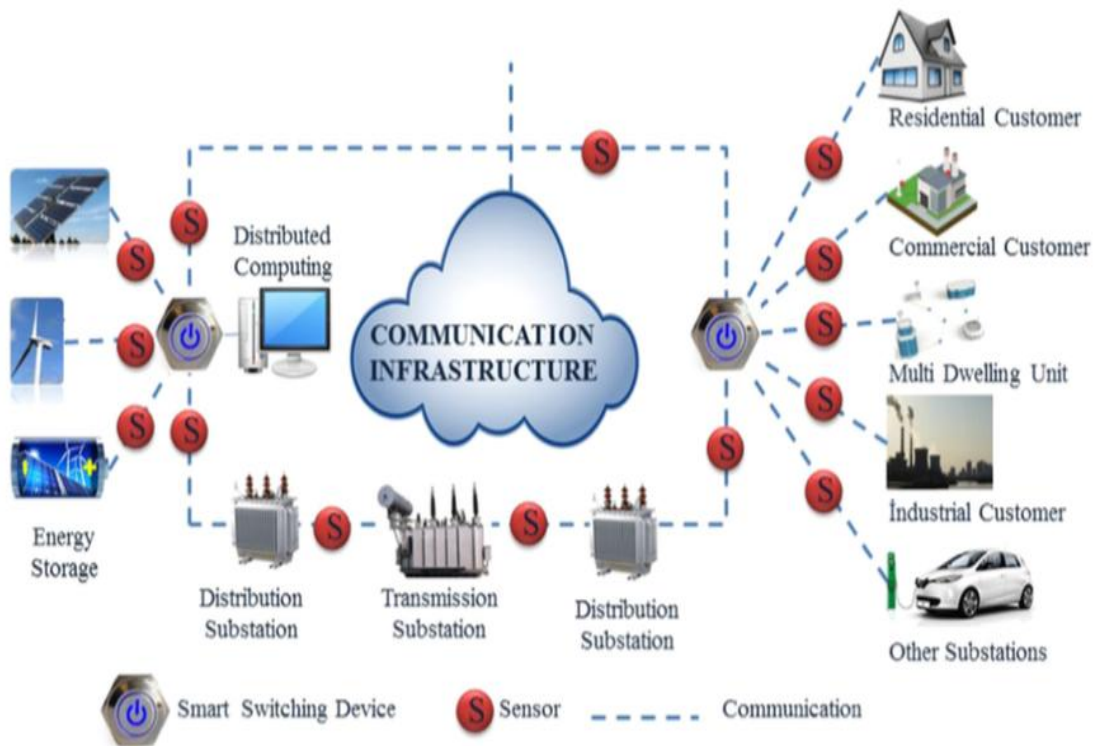

Fig. 3. Smart grid architecture increases the capacity and flexibility of the network and provides advanced modern communications technologies through sensing and control

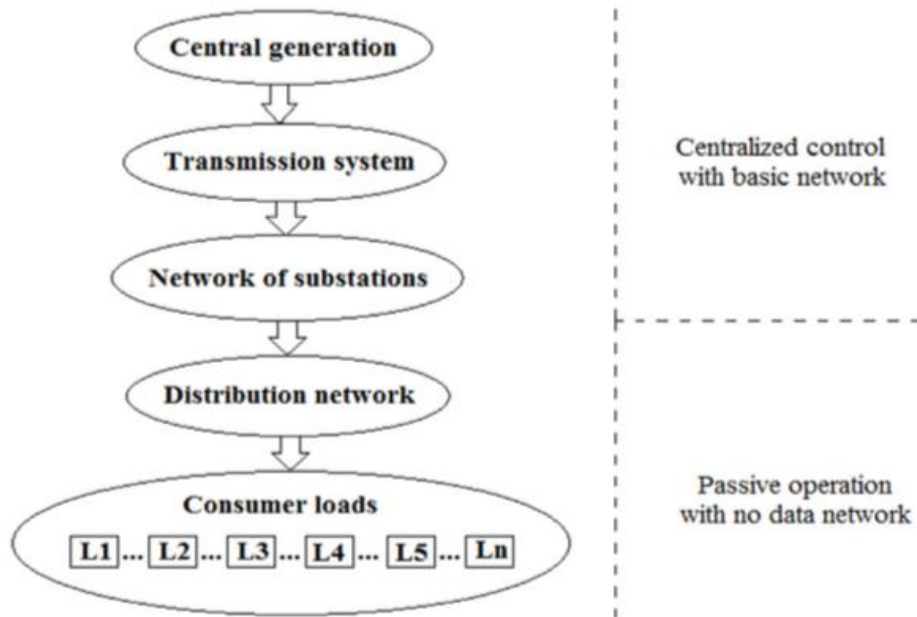

Fig. 4. Existing electricity utility grid

As depicted in the figure below, the distribution system's metering side has received the majority of recent infrastructure investments [11].

2.3 Evolution of the Smart Grid

Introduction of automatic meter reading in addition to quicker problem resolution. An example of cutting-edge visualization technology is the use of synchrophasors to measure voltage and current values in transmission lines. Processing and properly utilizing the data

detected by Smart Grid nerves is referred to as "adding brains." The main method doing this at the consumer level is DR. Energy usage by consumers is altered in response to a signal from utilities (DR). By integrating DERs, combined heat and power (CHP) facilities, and storage devices into the utility grid, the system can become more dependable and secure [12]. In order to allow power line communication and the integration of DERs, transmission and distribution lines are improved in a process known as "adding bones."

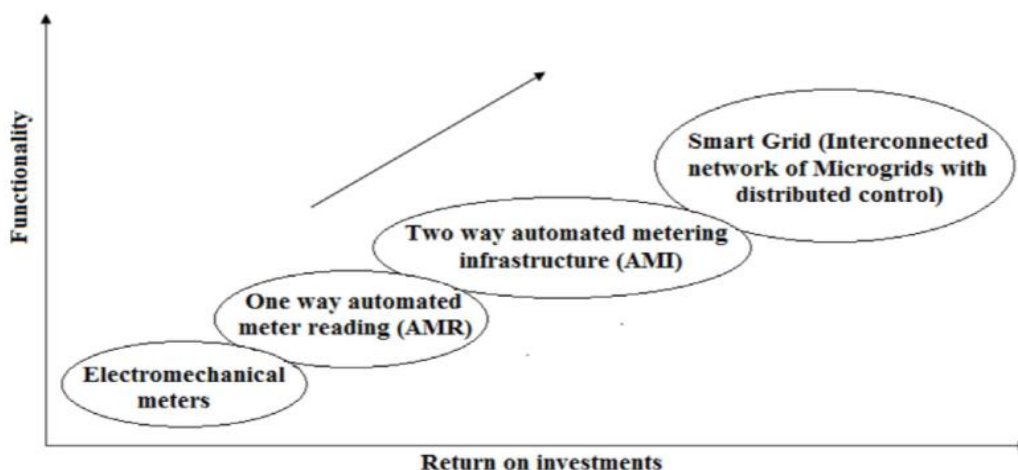

Fig. 5. Distribution system's metering side

2.4 Recent Advancement in Smart Grid Technology

There are various forms of advancement that has happened over time in the space of smart grid. The Table 1 shows the differences between smart grid and conventional Grid according to [13].

2.5 Advantages of Smart Grid Technology

A modern distributed power system that uses local, sustainable energy sources is known as a micro grid. Due to its independence from the main utility grid, it offers small communities energy security [14]. According to [15] below are some of the advantages of smart grid technology:

- Similar to a self-sustaining power grid, a micro grid can be disconnected from the utility grid in the event of a disturbance or power outage and can run independently. The micro grid outperforms the traditional electrical grid because to this feature.
- In the event of peak load demand and transient load, it can help the electric grid through load switching and load shaving.
- Because the micro grid can function entirely on renewable energy, it emits fewer greenhouse gases and is more environmentally benign.
- Customers are permitted to use both electricity and heat energy since micro grids make use of the DEGs. It will lower the cost of production and increase overall energy efficiency.
- By producing some or all of its own electricity needs, the micro grid can reduce its electricity tariff and charges to its customers.

2.6 Disadvantages of Smart Grid Technology

Although micro grid technology has many benefits, it also has a few minor downsides. According to [16] they following are enumerated:

- Although implementing a smart grid has numerous benefits and can be helpful in many ways, there are also disadvantages. One of the main negatives of a smart grid is that its overhead expenses are quite high and time-consuming, which would raise labor

costs; nevertheless, this new market for smart grids has the potential to lead to a completely new market for electricity, which would generate many employments.

- Another issue is that certain industries may be negatively impacted by the real-time charges of smart meters.
- In addition to the foregoing, installing a smart grid that uses the internet to deliver real-time grid information raises the danger of security and privacy breaches.

2.7 Hybrid Renewable Energy System

“The ability to create a hybrid system with other energy sources is the main benefit of renewable energy sources. Hybrid energy systems, in general, are those that combine the output of two or more different energy producing systems to meet an electrical or thermal load” [17].

There are hybrid renewable energy systems that can run on or off the grid. In rural and distant places, systems that operate independently of the grid are employed in conjunction with diesel generators to produce energy. Electricity generating (photovoltaic panels, wind turbines, hydro turbines, generators) and storage battery tools are needed in hybrid energy systems to meet the electrical energy demand of a distant or nearby facility, a rural or urban residence, a farm, and even a community. how many people are gathered?.

A hybrid renewable energy system with wind turbines and solar panels is seen in the figure below. In general, hybrid energy systems are made to assure the dependability of the electrical energy supply and/or due to the likelihood that a single renewable energy source in an energy system could be shut off at any time for reasons other than supplying the load. They are made to lower the cost per unit of electrical energy in a system that uses a traditional energy source.

In Europe, there has been research on both hybrid and non-hybrid renewable energy systems. According to the study, there is a concentration of research on PV / Grid, PV / Hydro, PV / Wind / Diesel, and PV / Wind. Carbon emissions from the burning of fossil fuels for energy today are bad for the environment. Renewable energy sources are the most widely held opinion in the globe because of their minimal carbon emissions and methods of use.

When we examine the study, we pay attention to the global trend toward hybrid or non-hybrid renewable energy systems. Since renewable energy systems are dependent on environmental factors, no system can operate at 100% efficiency all the time. A hybrid wind, PV, and diesel system, for instance, can supply wind continuity even when there isn't any sunbathing going on. When there is no wind or sunlight in such a hybrid system, the diesel generator is turned on to ensure supply security. The hybrid or non-hybrid renewable energy research distribution map for Europe identifies the nations that intend to implement systems.

2.8 Smart Grid Integration

The integration of renewable energy sources into the power system is one of the obstacles in the modernization of the electric grid and making the grid smart, even though several studies on renewable energy have been carried out to

investigate additional sources of clean energy. It might be challenging to transfer wind farm power into a grid when it is already quite crowded in some places. Renewable energy sources are erratic and unpredictable by nature. Historically, electricity has only ever gone in one direction, from a power plant to a client. Electricity must enter the grid from various areas, with additional sources coming from other sources. To integrate wind, solar, and other alternative sources into the distribution grid and move their energy to its destinations, contemporary controls, two-way power flow, and grid automation are required. To adapt solar photovoltaic and wind energy, coordinated efforts are required, and new devices in Smart Grid systems must be able to connect with existing hardware [18]. There are other computer tools for researching the integration of renewable energy into energy systems. In terms of applications, corresponding technology, and goals they achieve, these energy tools are various.

Table 1. Advancement in smart grid technology

Smart Grid	Conventional Grid
Two-way real-time communication	One-way communication
Distributed system of power generation	Centralized for power generation
Interconnected Network	Radial Network
A large number of sensors are involved	A small quantity of basic sensors are used
Digital Operation	Mechanical Operation
Automatic Control and Monitor	Manual Control and Monitor
Wide range of control	Limited control
Security and privacy concerns	No security or privacy concern

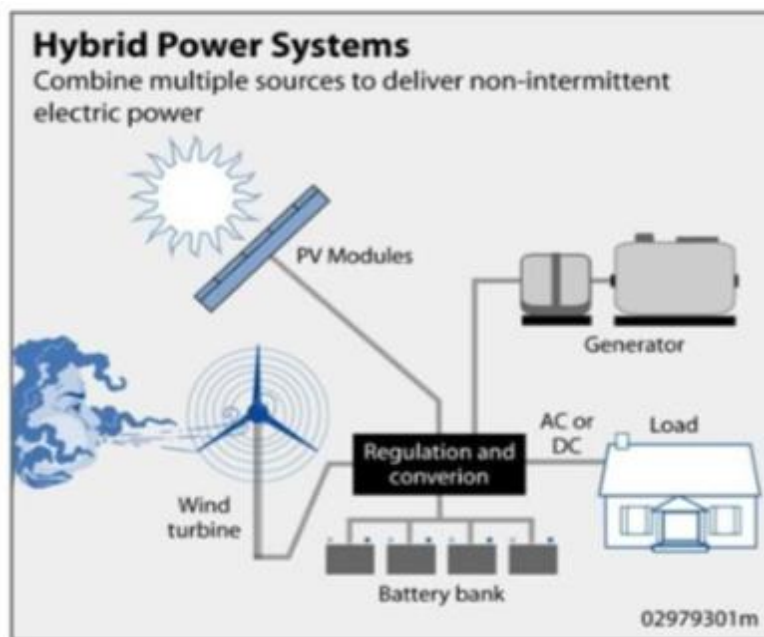

Fig. 6. Hybrid power system

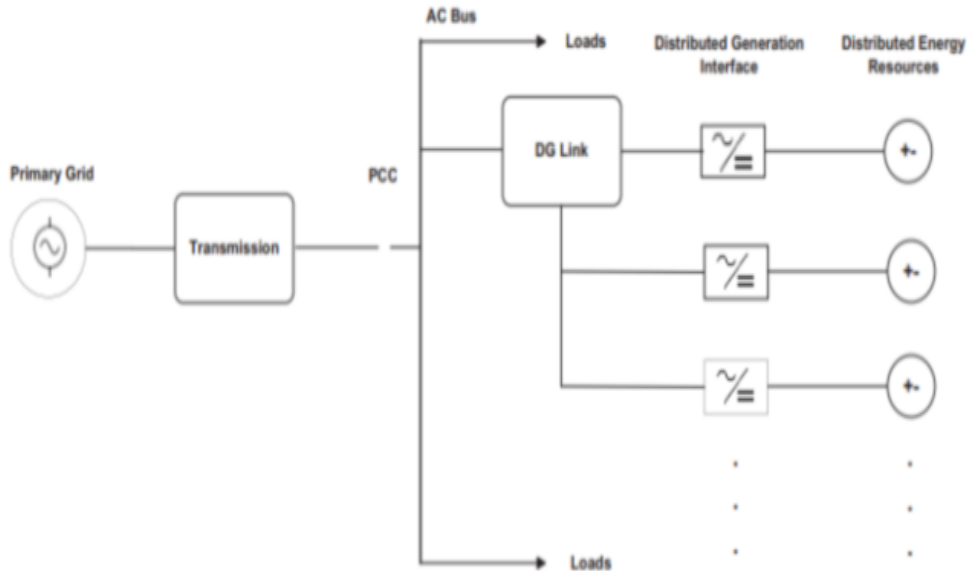

Fig. 7. Depicts a smart grid model that is dependable, scalable, and based on renewable energy, with generic components

Worldwide, feasibility and viability assessments are typical. These could serve as building blocks for various grid-connected renewable energy systems designed for certain localities. The viability of the system in Jos, Nigeria, was demonstrated by an investigation of an 80 kW solar PV-grid connected system utilizing HOMER energy optimization software [19]. A model for transient stability analysis was developed for a small, isolated grid supplied primarily by renewable sources, and it was used in El Hierro Island as an operation strategy to confirm that a reliable and efficient electrical system is achievable using a combination of wind and hydro units. The most dependable and cost-effective scenario (mix of renewable sources) for the area was discovered through optimization of seven isolated villages in the Almora District, State of Uttarakhand, India.

For the dispatchability and controllability of these resources as well as for the operation of the electricity system, the integration of renewable and distributed energy resources—covering large scale at the transmission level, medium scale at the distribution level, and small scale on commercial or residential buildings—can present challenges. By separating the generation and transmission of energy, energy storage devices, both electrical and thermal, can solve such issues. In addition to various types of demand response, smart grids can assist in automating

generation and demand control to ensure supply and demand balance [20].

The primary grid, which consists of a sizable generator together with an excitation system and secondary control, is the principal source of power supplied via traditional transmission lines. On the other hand, distributed generators in the form of renewable energy sources are connected to the grid utilizing static or dynamic coupling through power electronic converters and interfaces. During dynamic occurrences, the supervisory control maintains the continuity of the power supply [21]. The system switches to its landed mode, for instance, during blackouts or maintenance windows on the main grid side or transmission lines, and it continues to provide power using renewable energy sources. Distributed generators (or micro-grids) continue to run in coordination with the main grid if the dynamics continue to change.

The energy source must first supply electricity, and then the energy source must be integrated into the system by an inverter or converter before the components of distributed power systems may be counted.

Micro grids, which are subcategories of smart grids, offer us significant advantages in removing the challenges associated with the integration of renewable energy sources into the primary grid.

If we define micro grids under this area, we may state that they are networks of connected customers, power generators, and energy storage devices. These are actually small-scale systems for the production and delivery of electricity. When examining these systems, we can see that both electrical and thermal energy can be used (heating-cooling).

The resilience, efficiency, and transient performance of a smart grid system are being improved using methods based on cyber-physical system design [1].

3. CONCLUSION

The study shows an Overview of smart grid technology as a renewable energy source. As noted in the body of the work, smart grid technology is an electricity system that uses digital communications technology to detect, respond to, and take appropriate action in response to changes in demand and a variety of other problems. The work shows basic structure if a smart grid system, structure of classical power grid, evolution of smart grid, recent advancement in smart grid technology, advantages and disadvantages of smart grid technology as well as hybrid and smart grid integration.

COMPETING INTERESTS

Authors have declared that no competing interests exist.

REFERENCES

1. Aydin O, Demir Z. Smart grid integrated with hybrid renewable energy systems. Eskişehir Technical University Journal of Science and Technology. 2019; 120-131.
2. Xue-song Z. Research on smart grid technology. 2010 International Conference on Computer Application and System Modelling. China; 2010.
3. Arul A. An Analysis of Opportunities and Barriers of Integrating Renewable Energy with Smart Grid Technologies in India; 2015.
4. Maradin D. Advantages and Disadvantages of Renewable Energy Sources Utilization. International Journal of Energy Economics and Policy; 2021.
5. Ekanayake J. Smart grid technology and applications. UK: John Wiley and Sons; 2012.
6. Yesilbudak M. A novel intelligent approach for yaw position forecasting in wind energy systems. International Journal of Electrical Power & Energy Systems. 2015;406-413.
7. Blaifi SM. An enhanced dynamic model of battery using genetic algorithm suitable for photovoltaic applications. Journal of Applied Energy. 2016;888-898.
8. Colak I. The Effects of the Smart Grid System on the National Grids. 8th IEEE International Conference on Smart Grid. France; 2020.
9. Su W, Rahimieichi H, Zeng W, Chow M. A survey on the electrification of transportation in a smart grid environment. IEEE Trans. 2012;1-10.
10. Keyhani A, Hoboken N. Design of Smart Power Grid Renewable Energy Systems. USA: John Wiley & Sons, Inc; 2011.
11. Yilmaz M, Krein P. Review of benefits and challenges of vehicle-to-grid technology. IEEE Energy Covers; 2012.
12. Ekneligoda N, Weaver W. N.C. Ekneligoda, W.W. Weaver, Game theoretic optimization of DC micro- grids without a communication infrastructure, in: Proceedings of the 2014 Clem- Son Univ. Power Syst. Conf; 2014.
13. Yu Y, Luan W. Smart grid and its implementations. Proc CSEE. 2009;1-8.
14. Bayindir R. The Path of the Smart Grid - The New and Improved Power Grid. The Path of the Smart Grid -The New and Improved Power Grid. Istanbul, Turkey; 2016.
15. Hossain E. Micro grid testbeds around the world: State of art", Energy Conversion and Management. 2014;132-153.
16. Smebook. SMEBOOK; 2021. Retrieved from SMEBOOK: <https://smebook.eu/knowledge-base/smart-grids/what-are-the-disadvantages-of-smart-grids/>
17. Demir Z. Smart grid integrated with hybrid renewable energy systems. Eskişehir Technical University Journal of Science and Technology. 2019;120-131.
18. Gaviano A. Challenges and integration of PV and wind energy facilities from a smart grid point of view. Energy; 2011.
19. MS A. Viability of grid-connected solar PV energy system in Jos, Nigeria. Internal Journal for Electric Power. 2014;61-64.

20. Nnaemeka V.. Integrating Renewable Energy and Smart Grid Technology into the Nigerian Electricity Grid System. Scientific Research. 2014; 1-19.
21. Shahid A. Smart Grid Integration of Renewable Energy Systems. 7th International Conference on Renewable Energy Research and Applications,. Paris; 2018.

© 2022 Owunna and Obeagu; This is an Open Access article distributed under the terms of the Creative Commons Attribution License (<http://creativecommons.org/licenses/by/4.0>), which permits unrestricted use, distribution, and reproduction in any medium, provided the original work is properly cited.

Peer-review history:

The peer review history for this paper can be accessed here:
<https://www.sdiarticle5.com/review-history/92525>