

PAPER • OPEN ACCESS

Development and evaluation of a novel analyser for ISO14687 hydrogen purity analysis

To cite this article: K Arrhenius *et al* 2020 *Meas. Sci. Technol.* **31** 075010

View the [article online](#) for updates and enhancements.

You may also like

- [THE RELATIONSHIP BETWEEN INTERGALACTIC H I/O VI AND NEARBY \(\$z < 0.017\$ \) GALAXIES](#)
B. P. Wakker and B. D. Savage
- [A method to separate and quantify the effects of indentation size, residual stress and plastic damage when mapping properties using instrumented indentation](#)
X D Hou and N M Jennett
- [Research on Computer System Implementation of ISO14443B Protocol Communication Data Acquisition based on FPGA](#)
Guanjun Wang, Xuejun Liu and Wengao Sun

Development and evaluation of a novel analyser for ISO14687 hydrogen purity analysis

K Arrhenius¹ , Oliver B ker¹ , Andreas Fischer¹, Stefan Persijn² and Niamh D Moore³

¹ Research Institutes of Sweden AB (RISE), Brinellgatan 4, Bor s 50462, Sweden

² VSL, Dutch Metrology institute, Thijsseweg 9, JA Delft 2629, The Netherlands

³ National Physical Laboratory (NPL), Teddington, Hampton Rd TW11 0LW, United Kingdom

E-mail: karine.arrhenius@ri.se

Received 6 December 2019, revised 20 February 2020

Accepted for publication 5 March 2020

Published 4 May 2020



CrossMark

Abstract

Standards ISO14687 and EN17124 set stringent limits for numerous gaseous impurities and particulates that may damage the fuel cell system in a hydrogen vehicle, as it is highly sensitive to the presence of even very low levels of impurities. However, performing the whole set of analyses is both technically challenging and time-consuming for any laboratory and will require a combination of several analytical techniques or instruments. In this study, we discussed the selection of analytical techniques for hydrogen purity testing in order to optimize the CAPEX (capital expenditure) and OPEX (operational expenditure), while ensuring the quality of the results and the compliance of the analytical methods with ISO21087. Among the individual impurities to be analysed in ISO14687, spectroscopy techniques are suitable for ammonia, carbon dioxide, carbon monoxide, formaldehyde, formic acid, oxygen and water. Spectroscopy techniques are even suitable for some impurities belonging to the three total species such as hydrogen sulphide, hydrogen chloride and methane. However, helium and argon, which are monoatomic, do not exhibit response in the infrared region. Therefore, any spectroscopic analysis method must be completed by another method in order to simultaneously analyse all individual gaseous impurities from ISO14687. In this study, we constructed and demonstrated the feasibility of an instrument composed of a gas chromatograph having three columns (two packed columns and a PLOT (Porous Layer Open Tubular) column and two detectors (FID and TCD) coupled in parallel to two OFCEAS instruments using reference gas mixtures. Finally, we also proposed an extended configuration that will allow performing the whole set of analyses for gaseous species from ISO14687.

Keywords: hydrogen, hydrogen purity, analyser, OFCEAS, gas chromatography

(Some figures may appear in colour only in the online journal)

1. Introduction

Several countries are aiming to develop a sizable hydrogen fueling infrastructure over the next few decades [1–3]. In order

to facilitate this deployment, the quality of the hydrogen must be controlled, as the fuel cell system in a hydrogen vehicle is highly sensitive to the presence of even very low levels of impurities in hydrogen [4–7]. Therefore, standards ISO14687 [8] and EN17124:2019 [9] set stringent limits for numerous gaseous impurities and particulates that may damage the fuel cell. However, as shown by literature reviews of existing methods for offline testing of hydrogen purity [6, 10], performing the whole set of analyses is both technically challenging



Original content from this work may be used under the terms of the [Creative Commons Attribution 4.0 licence](https://creativecommons.org/licenses/by/4.0/). Any further distribution of this work must maintain attribution to the author(s) and the title of the work, journal citation and DOI.

and time-consuming for any laboratory, and will require a combination of several analytical techniques or instruments [11]. The most common techniques currently in use or under development by hydrogen purity laboratories are gas chromatography techniques (e.g. GC-ECD, GC-FID, GC-MS,...), which are suitable for stable species as helium, nitrogen and argon, as well as for many compounds belonging to one of the three total species (sulphur, hydrocarbons and halogenated) and infrared spectroscopy methods, which are suitable for small species, both stable ones like methane and carbon monoxide as well as reactive species such as ammonia, formaldehyde and formic acid. Quality insurance is another aspect that needs to be tackled when implementing ISO14687. It is now mandatory for the implementation of ISO14687 to ensure that the validation requirements set in ISO21087 [12] are met. Only in this case, the methods can be considered as fit-for-purpose for hydrogen purity testing. The validation parameters to be assessed include limit of detection, working range, selectivity, precision, trueness and measurement uncertainty. According to ISO21087, the relative combined uncertainty at concentrations close to the threshold value should be below 10% of the concentration for an amount fraction equal to or above 10 nmol mol^{-1} . This in turn implies that precision and trueness must be small enough to fulfill the criterion on the combined standard measurement uncertainty. Ideally, certified reference materials shall be used to determine the bias for the trueness. Due to the large number of impurities to analyse at stringent detection limits, the capital expenditure (CAPEX) required to develop a hydrogen purity laboratory has recently been estimated to be around €500 000 [13]. The acquisition of analytical instruments involves both technical and financial considerations. Another factor to consider is related to the operational costs (also referred to as OPEX for operational expenditures). Costs included in the CAPEX and the OPEX cover not only the analytical instrument itself [14] but also costs for commissioning, installation, training, utilities, expenses for quality controls, calibration, analysis and maintenance.... In most laboratories, labor costs comprise a large part of the total operational budget [15] so the turnaround time (from sample registration to results reporting) is critical. Nowadays, strategies for implementing hydrogen purity testing must not only optimize costs but must also achieve and maintain quality according to the requirements set in ISO21087.

In this study, we discussed the selection of analytical techniques for hydrogen purity testing in order to optimize the CAPEX and OPEX while ensuring the quality of the results. Based on this discussion, a novel analyser for hydrogen purity testing, combining gas chromatographic and spectroscopy techniques in one instrument, was then built, and the performances of the instrument were evaluated. Next to a reduced volume of hydrogen sample needed, the main benefit would be to save time and reduce the overall analysis costs, which is critical to enable the development of a sustainable hydrogen infrastructure. Currently, the cost to analyse one sample of hydrogen is evaluated to be between €6000 to €11 000 depending of the number of samples analysed at the same time. To the cost of analysis, the cost for sampling, evaluated to be around

€4000, needs to be added. Labour and other running costs for sampling and analysis are the largest contributions to the total cost [16].

2. Selection of the analytical techniques

A review of the state-of-art analytical methods (including characteristic performances mainly regarding detection limits and range) was recently performed as part of the project MetroHyVe [17]. Existing methods are currently mainly based on two main analytical instrument principles: chromatography with or without pre-concentration, and infrared spectroscopy. Other techniques include different types of sensors, hygrometers etc.

Among spectroscopy methods, three techniques can analyse seven to eight impurities among the 13 individual gaseous species from ISO14687 at the required thresholds: Fourier Transform Infrared Spectroscopy (FTIR), Optical Feedback Cavity Enhanced Absorption Spectroscopy (OFCEAS) and Cavity Ring Down Spectroscopy (CRDS).

Instead of sequentially irradiating the sample with varying single wavelengths (dispersive), FTIR allows us to collect all spectral data in one go. For this, a continuum source of light is needed to produce light over a broad range of infrared wavelengths. The infrared light then passes through an interferometer and is afterwards directed at the sample. This yields an interferogram; a somewhat raw signal, which represents the intensity of light as a function of the position of a mirror. The signal first needs to be Fourier-transformed (FT) to produce the more familiar IR plot of intensity versus wavenumber; hence the name 'FT-IR' or FTIR. FTIR is basically an interferometer in which infrared light from a continuum source is split into two by a beam splitter, a device passing about half of the light to a movable mirror while redirecting the other half to a fixed mirror. One of the arms of the interferometer contains a cell with the gas sample to be analysed. Both beams are redirected to the beam-splitter where they are recombined and directed to a detector. The recorded signal is transformed via a Fourier transformation into an absorption spectrum. The FTIR method for hydrogen purity is described in the ASTM D7653-10 [18].

CRDS is based on the measurement of the decay rate of the light intensity leaking out of a high-finesse cavity rather than the change of intensity due to the absorption. The beam from a single-frequency laser enters a cavity defined by two or three high reflectivity mirrors. When the laser is on, the cavity quickly fills with circulating laser light. A fast photodetector senses the small amount of light leaking through one of the mirrors to produce a signal that is directly proportional to the intensity in the cavity. When the photodetector signal reaches a threshold level, the laser is rapidly turned off. The light already within the cavity continues to bounce between the mirrors, but because the mirrors have slightly less than 100% reflectivity (but typically >99.995% in the near-infrared), the light intensity inside the cavity steadily leaks out and decays to zero in an exponential fashion. This decay, or 'ring down', is measured in real time by the photodetector, and the amount

of time it takes for the ring down to occur is determined solely by the reflectivity of the mirrors (for an empty cavity). The CRDS method for hydrogen purity is described in the ASTM D7941/D7941M-14 [19].

The presence of gas species in the cavity that absorbs the laser light results in a second loss mechanism within the cavity (absorption). This accelerates the ring down time compared to a cavity without any additional absorption due to a targeted gas species. The final concentration data are derived from the difference between these two ring-down times and are therefore independent of laser intensity fluctuations or absolute laser power. This produces precise, quantitative measurements that account for any intra-cavity loss that may be changing over time, and it allows the discrimination of loss due to absorption from losses due to the cavity mirrors.

OFCEAS is another cavity-based spectroscopy method, but it relies on direct intensity measurement rather than the estimate of a ring down time. A varying current is applied to the temperature-controlled laser source, enabling the tuning of the laser to the frequencies of resonance modes of the cavity. Cavity-enhanced absorption spectroscopy relies on a continuous coupling of laser light to the cavity, which requires the laser frequency to be actively locked to one of the cavity modes. In OFCEAS, this is accomplished by optical feedback to the laser. The laser coupling is arranged to permit a restrained return of the resonant intracavity field back to the laser while avoiding a reappearance of light directly reflected from the cavity input mirror. The feedback phenomenon drastically increases the spectral purity of the laser source. The optical cavity serves to trap the light so that it passes through the sample gas multiple times as it is reflected by the cavity mirrors. The resulting effective path length is typically several kilometers.

Despite the difference in instrumentation, all spectroscopic techniques share several common features. Infrared spectroscopy is based on the energies induced by the movement of the bonds between two different atoms. Among the individual impurities to be analysed in ISO14687, spectroscopy techniques are suitable for ammonia, carbon dioxide, carbon monoxide, formaldehyde, formic acid, oxygen and water. Helium and argon, which are monoatomic, do not exhibit a response in the infrared region. Spectroscopy techniques are even suitable for some impurities belonging to the three total species such as hydrogen sulphide, hydrogen chloride and methane.

According to providers from these different technologies, it will require at least two OFCEAS instruments coupled in series to analyse water, oxygen, carbon dioxide, carbon monoxide, formaldehyde, formic acid, ammonia, methane and hydrogen sulphide. Similarly, it will require four to five CRDS instruments coupled in parallel to analyse the same compounds with the exception of formic acid. The commercial CRDS instruments are less suitable for detecting 'large' molecules (bigger than methanol such as C2, C3 and formic acid), as these molecules have broad absorption spectra to the contrary of molecules such as CH₄, CO, CO₂ or CH₂O. However, it is possible to detect formic acid by using a custom-built wider tunability [20]. Finally, a single FTIR instrument is

needed but the analysis of oxygen cannot be performed. Diatomic gases such as O₂, N₂ and H₂ cannot be detected as they do not have absorbance bands in the infrared region of the spectrum.

As explained above, none of these spectroscopic techniques are suitable for helium, argon and nitrogen. Therefore, any spectroscopic analysis method must be completed by another method in order to simultaneously analysed all individual gaseous impurities from ISO14687.

Among chromatographic methods, GC-MS and GC-PDHID are the most versatile as they each enable the quantification of six to seven of the 13 gaseous species from ISO14687 [17]. However, as nitrogen, argon and helium threshold values in ISO14687 are not analytically challenging (as all above 100 ppm-vol), GC-FID-TCD is a relatively inexpensive and performant method that can complement spectroscopic methods for the range of concentrations required for N₂, Ar and He. GC-FID-TCD is already widely used in the fields of petrochemical, chemical and energy industries for permanent gases.

Therefore, by combining GC-FID-TCD and OFCEAS analysers into one instrument, all individual impurities from ISO14687 can theoretically be analysed simultaneously. Even some of the compounds from the total species such as CH₄, H₂S and HCl, and other hydrocarbons than methane can be analysed at the requested threshold values using these two techniques combined. In this case, it would require the use of at least three GC-columns and two to three OFCEAS instruments.

ISO14687 also include 'total' species; halogenated, sulphur and hydrocarbons will require more specific detectors such as GC-SCD, mainly to reach the challenging detection limit set for sulphur compounds. Total species belong in the risk assessments over the probability of presence in the hydrogen produced by either steam methane reforming (SMR), chlor-alkali process, polymer electrolyte membrane water electrolysis and alkaline electrolysis [21] to the category 'unlikely'. A review of available hydrogen purity reports has been performed as part of the MetroHyVe project. In total, 32 hydrogen purity reports from 24 different Hydrogen Refueling Stations (HRS) stations were reviewed [22]. Very few halogenated compounds (dichloromethane, tetrachloroethylene and tetrachlorohexafluorobutane) or sulphur compounds (COS, CS₂ and H₂S) have yet been found in hydrogen samples dispensed at HRSs. However, a total of 12 hydrocarbons including oxygenated hydrocarbons have been found. Most of these compounds (acetone, ethane, ethanol, isopropyl alcohol, propane, isobutane and n-butane) can be analysed with the system build in the study. Only the detection of heptane, cyclohexane, octene and decene would require a more sensitive method. Moreover, these compounds can only be identified with good confidence using, for instance, mass spectrometry rather than by only their retention time as it is the case with GC-FID, which is a detector with low specificity.

In this study, we constructed an instrument composed of a gas chromatograph having three columns (two packed columns and a plot-column) and two detectors (FID and TCD) coupled in parallel to two OFCEAS instruments. This measurement set-up allows the simultaneous analyses of

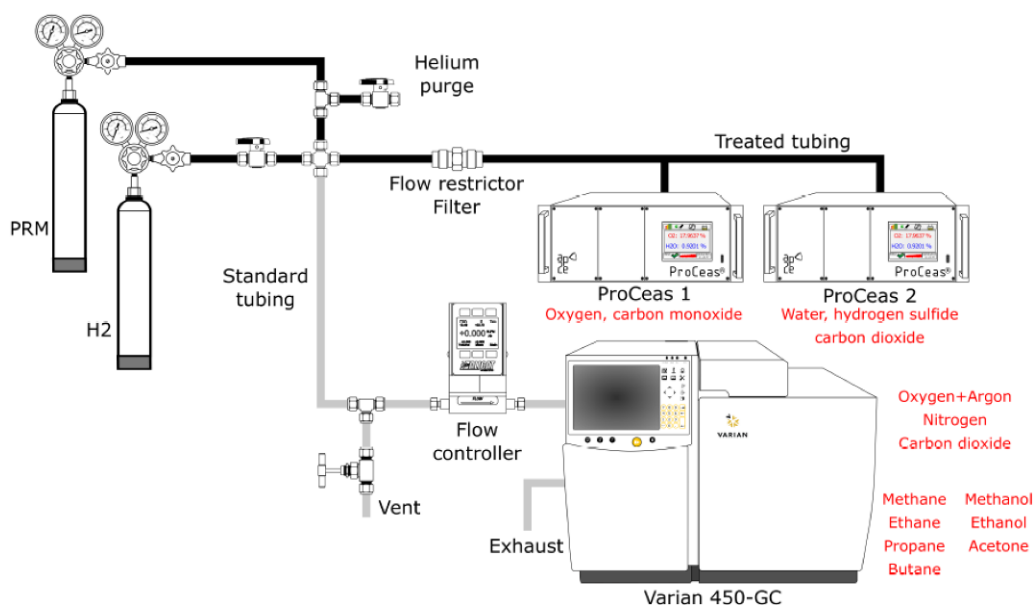

Figure 1. Scheme of the OFCEAS-GC/FID-TCD system for hydrogen purity.

oxygen, carbon monoxide, carbon dioxide, water, nitrogen, argon, methane and other hydrocarbons such as ethane, propane, butane, isobutane, methanol, ethanol and acetone. These impurities cover the impurities that are listed as ‘frequent’, ‘possible’, ‘rare’ and ‘very rare’ in risk assessments over the probability of presence of impurities in the hydrogen produced by either steam methane reforming (SMR), chlor-alkali process, polymer electrolyte membrane water electrolysis and alkaline electrolysis [21], with the exception of formaldehyde which is listed as ‘very rare’ when the hydrogen is produced by SMR. The flow rate to the OFCEAS was controlled by an internal pump while a mass flow controller was installed upstream the GC system to control the flow in the GC system. A tee-connection installed after the cylinder containing the hydrogen sample allowed either the introduction of hydrogen (or helium), which can be used to confirm that the system is air-tight, or the introduction of primary reference gas standards, which are used to calibrate the system.

3. Experimental

3.1. The instruments and the set-up

The three instruments (two OFCEAS instruments and a GC system) were connected as shown in figure 1.

The instrument combined a Varian 450-GC-TCD/FID (gas chromatograph/thermal conductivity detector/flame ionisation detector) equipped with three columns with two OFCEAS instruments. The configuration of the GC is as follows:

- A Hayesep Q, 80–100 Mesh, 1.8 m × 1/8'' × 2.0 mm connected to the TCD.
- A molecular Sieve 5A, 60–80 Mesh, 1 m × 1/8'' × 2.0 mm connected to the TCD.
- A PoraBOND Q, 25 m × 0.53 mm × 10 μm connected to the FID.

The instrument has also three 6-port valves. A mass flow controller set to 500 Nml min⁻¹ allows the gas (hydrogen sample, Primary Reference Mixture (PRM) or helium) to reach the first 6-port valve where a sampling loop of 100 μl is connected between the ports 2 and 3 and the second 6-port valve having the same configuration but with a sampling loop of 500 μl. The sampling loops are filled during 10 s after which the 6-port valves are switched. The content of the first loop is introduced into the first packed column (Hayesep), while the content of the second loop is introduced into the PLOT-column. A third 6-port valve allows us to change the direction of the carrier gas in the second packed column. While H₂, He and Ar have reached the detector, O₂, N₂ and CO have reached the second column (Molecular Sieve), and CH₄ and CO₂ are still retained in the first column; the valve is switched causing the direction of the flow in the columns to change and the Molecular Sieve column to be by-passed. During this lapse of time, CH₄ and CO₂ reached the detector. Finally, the valve is switched again so O₂, CO and N₂ can be separated and detected.

Two custom-built optical feedback cavity enhanced absorption spectrometers (OFCEAS—ProCeas from AP2E) were developed for the measurement of O₂ and CO (instrument 1) and CO₂, H₂O and H₂S (instrument 2). Gas samples are introduced into the measurement cells at a flow rate of 100 ml min⁻¹ through a sulfinert-treated stainless steel restrictor using an internal pump. The measurement cell consists of a multi-path cavity equipped with highly reflective mirrors, allowing path lengths up to 10 km. The cell was kept at a pressure of 50 mbar and at a temperature of 40 °C. To minimize ingress of particulate matter into the instrument, a sulfinert-treated stainless steel particle filter with a 7 micron pore size was also installed upstream of the instruments. The instruments were pre-calibrated for O₂ concentrations from 1 μmol mol⁻¹ to 2000 μmol mol⁻¹, for CO₂ concentrations from 0.2 μmol mol⁻¹ to 2000 μmol mol⁻¹,

Table 1. Gravimetric composition of the reference gas mixture used for the evaluation of the OFCEAS-GC/FID-TCD system.

Cylinder NPL 2358 R	
Matrix →	H ₂
Cylinder type →	Spectra-Seal with NPL proprietary treatment
Component (%) ↓	Gravimetric amount fraction (μmol mol ⁻¹)
CO	0.48 ± 0.02
CO ₂	5 ± 0.2
CH ₄	238 ± 6
C ₂ H ₆	2.44 ± 0.07
O ₂	—
Ar	704
N ₂	703
He	701

for H₂O from 0.05 μmol mol⁻¹ to 500 μmol mol⁻¹, for H₂S from 0.001 μmol mol⁻¹ to 2 μmol mol⁻¹ and for CO from 0.002 μmol mol⁻¹ to 20 μmol mol⁻¹. For each compound, a three-point calibration was performed; at the lowest and highest values of the concentration range as well as in the middle of the range.

3.2. Primary reference materials (PRMs)

Accurate gas mixtures were needed to characterize the measurement technique described above. A parent reference mixture was gravimetrically prepared by NPL from the pure components (CO, CO₂, CH₄, Ar, N₂ and He) in accordance with ISO 6142-1 [23] at a nominal value of 30 000 μmol mol⁻¹ each of argon, nitrogen and helium, 10 000 μmol mol⁻¹ methane, 200 μmol mol⁻¹ carbon dioxide, 100 μmol mol⁻¹ ethane and 20 μmol mol⁻¹ carbon monoxide in hydrogen balance gas. It corresponds to approximately 100 times the EN17124:2018 threshold values.

This pre-mixture was gravimetrically diluted in hydrogen balance gas approximately nine times in accordance with ISO6142-1 to produce a nominal mixture of 2700 μmol mol⁻¹ each of argon, nitrogen and helium, 900 μmol mol⁻¹ methane, 20 μmol mol⁻¹ carbon dioxide, 9 μmol mol⁻¹ ethane and 1.8 μmol mol⁻¹ carbon monoxide.

The final mixture (NP L2358 R) was prepared by gravimetric dilution of this mixture in accordance with ISO6142-1 to produce an approximate nominal mixture of 700 μmol mol⁻¹ each of argon, nitrogen and helium, 230 μmol mol⁻¹ methane, 5 μmol mol⁻¹ carbon dioxide, 2.5 μmol mol⁻¹ ethane and 0.5 μmol mol⁻¹ carbon monoxide. This final reference mixture was validated using an in-house primary reference material prepared at NPL. The cylinder was then sent to RISE in Sweden, where the system was tested.

The gravimetric composition of the reference mixtures used in this study is reported in table 1.

4. Evaluation of the system

A method can only be considered as fit-for-purpose for hydrogen purity testing if its performances meet the criteria set out in ISO21087 [12]. Limits of detections, limits of quantification,

working ranges, precisions, trueness and measurement uncertainties were thus determined for each species analysed with the OFCEAS-GC/FID-TCD system.

4.1. Limit of detection and limit of quantification

According to the manufacturer and tests performed in previous studies [24, 25], the methods and instruments selected for this study individually exhibit detection limits at least three times lower than the thresholds set in ISO14687, which is in accordance with the criterion on the detection limit set out in ISO21087 ($x_{LOD} + \mu_{LOD} < x_{threshold}$). In this study, the limits of detection obtained for each impurity with the OFCEAS-GC/FID-TCD system were evaluated either using the method based on the signal-to-noise (S/N) ratio approach for the species detected by FID or TCD or the method based on standard deviation for blank samples (i.e. matrices containing no detectable analyte) for species detected by OFCEAS. The determination of the S/N ratio was performed by comparing measured signals from a gas containing known low concentrations of analytes with those of blank samples and by establishing the minimum concentration at which the analyte can reliably be quantified. A typical S/N ratio for x_{LOD} is 3:1 and for x_{LOQ} 10:1. For the detection limit, 50 times dilutions of a certified reference gas mixture containing hydrocarbons from C1; methane to C5; pentane and isopentane at 100 μmol mol⁻¹ was used. The final concentration for methane, ethane, propane, isobutane, butane, isopentane and pentane was around 2 μmol mol⁻¹ each. The x_{LOD} was estimated to be 0.04 μmolC mol⁻¹ for methane, 0.1 μmolC mol⁻¹ for ethane and 0.3 μmolC mol⁻¹ for C3 hydrocarbons, 0.4 μmolC mol⁻¹ for C4 and C5 hydrocarbons.

The limits of detection (x_{LOD}) for the species detected by OFCEAS were evaluated using blank samples as shown in figure 2 for hydrogen sulphide. The standard deviation s_0 was calculated using the following equation:

$$s_0 = \sqrt{\frac{1}{N-1} \sum_{i=1}^N (x_i - \bar{x})^2} \quad (1)$$

where x_i is the measurement i , \bar{x} is the average value, and N is the number of replicates, here $N = 14$.

The results obtained for the 14 blank measurements are presented in table 2. The standard deviation (s_0) calculated using equation (1) was estimated to be 0.55. The x_{LOD} and x_{LOQ} were then calculated according to equations (2) and (3):

$$x_{LOD} = 3 \cdot s_0 \quad (2)$$

$$x_{LOQ} = kQ \cdot s_0 \quad (3)$$

According to ISO21087, kQ should be 3 when specification values (thresholds) are equal to or less than 10 nmol mol⁻¹,

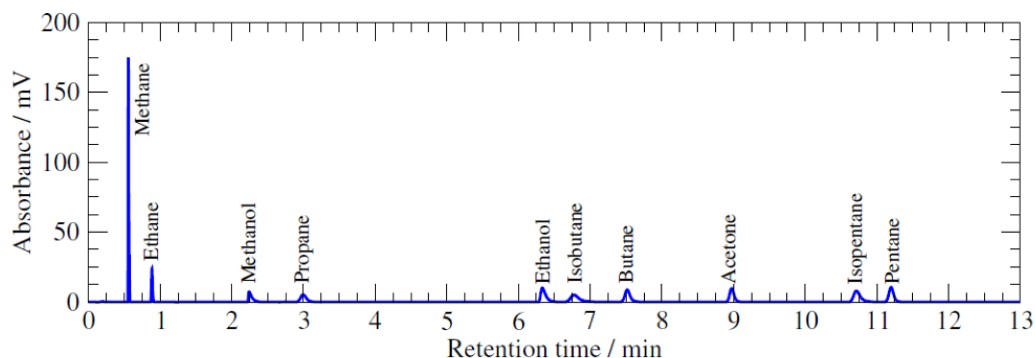

Figure 2. Chromatogram of hydrocarbons and oxygenated hydrocarbons using the OFCEAS-GC/FID-TCD system.

Table 2. Measured OFCEAS signal for H₂S when analysing blank samples (pure hydrogen).

Measurements	Values in nmol mol ⁻¹	$x_i - \bar{x}$
1	1.1	0.392857
2	0.8	0.092857
3	1.4	0.692857
4	0.9	0.192857
5	1.1	0.392857
6	0.9	0.192857
7	1.3	0.592857
8	1.1	0.392857
9	0.9	0.192857
10	0.6	-0.10714
11	-0.4	-1.10714
12	0.2	-0.50714
13	-0.1	-0.80714
14	0.1	-0.60714

meaning that the limit of quantification is equal to the limit of detection. In this case, $x_{LOD} = x_{LOQ} = 1.6 \text{ nmol mol}^{-1}$. The detection for the all compounds that can be analysed with the system is presented in table 3 together with the thresholds in ISO14687 for comparison.

For all species, μ_{LOD} was calculating and found to never exceed 50% of the x_{LOD} . Detection limits for all the species measured with the OFCEAS-GC/FID-TCD system are therefore low enough to meet the criterion set out in ISO21087.

4.2. Working ranges

According to ISO21087, for the analysis of impurities in hydrogen, the higher value of the working range shall be at least equal to twice the threshold value, while the lower end of the working range is generally bounded by the limit of quantification. Both GC detectors (FID and TCD) are known to have a linear dynamic range of at least 10^4 , indicating a linearity of response to compounds over a 10 000-fold concentrations [26].

Table 3. Detection limits for the compounds analysed with the of the OFCEAS-GC/FID-TCD system compared with the threshold values in ISO14687-2.

Compounds	ISO 14687-2 threshold [$\mu\text{mol mol}^{-1}$]	Instrument's limits
Water H ₂ O	5	0.05
Methane CH ₄	2	0.04
Oxygen O ₂	5	1
Helium He	300	—
Nitrogen N ₂	100	30
Argon Ar	100	30
Carbon dioxide CO ₂	2	0.2
Carbon monoxide CO	0.2	0.002
Total sulphur compounds	0.004	—
H ₂ S	—	0.0016
Formaldehyde HCHO	0.01	—
Formic acid HCOOH	0.2	—
Ammonia NH ₃	0.1	—
Total halogenated	0.05	—
C2 hydrocarbons	2	0.1
C3 hydrocarbons	2	0.3
C4 hydrocarbons	2	0.4
C5 hydrocarbons	2	0.4
C6–C18 hydrocarbons	2	—

4.3. Selectivity

The selectivity refers to the capability of the method to discriminate and quantify the response of target component in the presence of other components as interference [27]. The two selected analytical techniques are known to have good selectivity; the GC techniques due to the separation of compounds within the GC column and the OFCEAS due to the selective optical feedback from the cavity resonance [28].

In gas chromatography, the selectivity is the relative retention of two adjacent peaks; hence, it is highly dependent on the change of the retention time values of the two corresponding target gas components. The choice of the column is determinant to achieve a good selectivity. In this study, we used a porous-layer open tubular column (PLOT-column) in which a porous solid support is attached to the capillary's inner wall, which gives a good selectivity for the components analysed by FID, as can be seen in figure 2.

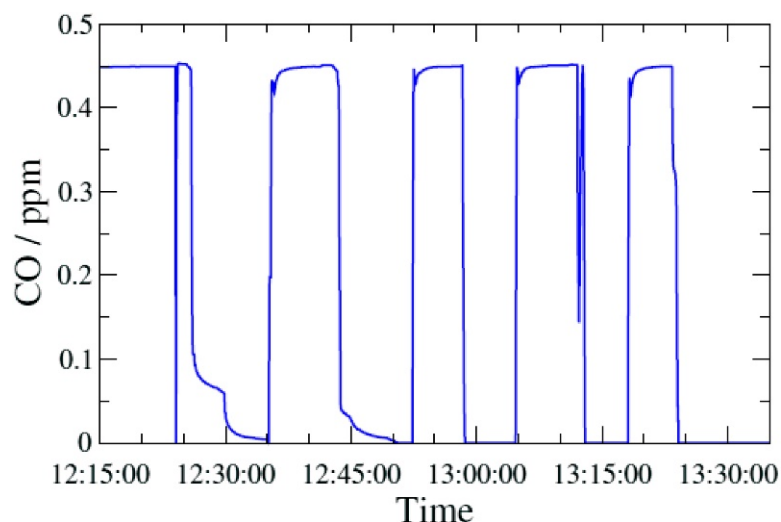

Figure 3. Duplicate CO measurements with OFCEAS method.

However, with the GC-TCD, argon and oxygen coelute. Oxygen being also measured by the OFCEAS technique, a method of subtraction can be applied to calculate the amount of argon.

The selectivity for OFCEAS methods is usually described as very good, as the measurement principle allows the identification of absorption peaks with a very narrow spectral width. The optical power is closely concentrated around the carrier frequency, defining the laser linewidth. However, some residual optical power is still present far away from the emission line and may then overlap with different cavity resonances [27]. In order to test the selectivity of the method for hydrogen sulphide for example, hydrogen sulphide concentrations were measured in gas samples to which specific interferences were deliberately introduced (CO, CO₂, O₂, H₂O and CH₄).

It was found that only high amounts of CO₂ (4000 $\mu\text{mol mol}^{-1}$) altered the response of the analyser when measuring H₂S. The gas also contained 40 $\mu\text{mol mol}^{-1}$ of CO, 480 $\mu\text{mol mol}^{-1}$ of O₂, 900 $\mu\text{mol mol}^{-1}$ of CH₄ and 550 $\mu\text{mol mol}^{-1}$ of H₂O. None of these compounds affected the H₂S signal.

Thus, there should be no interference versus other impurities from ISO14687.

4.4. Precision

For most species, precision was estimated using the reference gas mixtures described in section 3.2. However, as no certified reference material containing H₂S (for example) at concentration close to 2 nmol mol^{-1} was available, the within-laboratory reproductibility $u(R_w)$ was calculated from spiked samples at 10 nmol mol^{-1} . For methane, 50 times dilutions of a certified reference gas mixture containing hydrocarbons from C1 to C5 at 100 $\mu\text{mol mol}^{-1}$ were used.

The intermediate precision was calculated by analysing duplicates and pooling the standard deviation. The results for CO are shown in figure 3.

Table 4. Within-laboratory reproductibilities, method biases and expanded uncertainties from the OFCEAS-GC/FID-TCD system for hydrogen purity.

Compounds	$u(R_w)$ rel.	$u(\text{bias})$ rel.	$U = 2 \cdot u_c$
Methane CH ₄	3.39	1.61	7.5
Helium He	1.98	2.86	7.0
Nitrogen N ₂	2.74	2.56	7.5
Argon Ar	3.01	3.28	8.9
Hydrogen sulphide H ₂ S	2.20	3.59	8.4
Carbon monoxide CO	2.26	3.38	8.1
Ethane C ₂ H ₆	3.34	2.97	9.0

The within-laboratory reproductibility was calculated using the software MUKit Measurement Uncertainty kit. This software is based on Nordtest report 537 [29], where uncertainty is estimated using quality control and validation data. The within-laboratory reproductibilities $u(R_w)$ are presented in table 4.

4.5. Trueness

The method bias $u(\text{bias})$ close the limit of detection was calculated from spiked samples at 20–30 nmol mol^{-1} H₂S and using the reference gas mixtures described above for CO, CO₂, He, N₂, Ar and CH₄. The method biases $u(\text{bias})$ calculated using the software MUKit Measurement Uncertainty kit are presented in table 4.

4.6. Measurement uncertainties

The expanded uncertainties ($k = 2$) were calculated using the software MUKit Measurement Uncertainty Kit.

The performance characteristics and the measurement uncertainty were compared to the criteria stated in ISO21087 and the method was found to be fit-for-purpose.

5. Conclusion

The tests performed in this study demonstrated the feasibility of an instrument combining a gas chromatograph coupled to a FID and a TCD detector and two Proceas. In total, the system can analyse simultaneous six individual impurities: oxygen, nitrogen, argon, carbon monoxide, water and carbon dioxide, as well as other compounds belonging to the ‘total species’ families such as methane, ethane, propane, butanes, pentanes, methanol, ethanol, acetone and hydrogen sulphide. This covers almost all impurities with the probabilities of presence ‘frequent, possible, rare and very rare’ for the four production methods; chlor-alkali process (membrane cell process), PEM water electrolysis process with TSA, alkaline electrolyser and steam methane reforming with PSA with the exception of formaldehyde (very rare with steam methane reforming with PSA) and most of the impurities belonging to the ‘total families’ that have so far been identified in real hydrogen samples.

The instrument developed here required no lengthy calibration or set up. Five points calibration for all six compounds can be performed in about 1 h. The total analysis time is controlled by the GC-FID system. The analysis time is 12 min for all impurities mentioned above; thus two consecutive analyses of the same sample can be performed in less than 30 min. The flow into the GC system is 500 Nml min⁻¹ and into the Proceas 100 ml min⁻¹. A flow of 200 ml min⁻¹ is also needed for the vent. So in total, the system requires a flow of 800 ml min⁻¹, which represents 24 l per hydrogen fuel.

Multiple analyses can be undertaken during one day (around 12 hydrogen samples). For one unique sample, results are produced in less than two hours, which directly impacts the turnaround time.

All things considered, the improvements, mainly of the turnaround time, represent a potential 15% to 30% gain in OPEX optimization; as in most laboratories, labor costs comprise 60%–70% of the total operational budget (element of a typical laboratory budget). With an optimized OPEX and accurate results, the system presented here is a viable option for a hydrogen purity laboratory.

By using hydrogen as a carrier gas in the GC/TCD, the system could potentially analyse helium as well if the GC parameters (mainly GC oven temperature and TCD filament temperature) are optimized. Another Proceas for ammonia, formaldehyde and formic acid has been developed by AP2E as part of the MetroHyVe project. This instrument could be installed in series after the two other Proceas. Finally, another study also performed as part of the MetroHyVe project has shown that most of the other impurities from the total families which are not covered by the instrument described here can be quantitatively retained on one unique sorbent. This thermal desorption-gas chromatography-FID/MS technique will provide not only a sum of concentrations, but also an identification of which compound(s) is/are actually present in the hydrogen. The most suitable sorbent appeared to be TCC, a three-bed sorbent, containing a weak (Tenax TA), a medium (Carbograph 1TD) and a strong sorbent (Carboxen 1003).

The total CAPEX for instruments (incl. installation and training) proposed here will be around €380 000 (GC/TCD/FID €50 000 to €60 000; 3 Proceas: €180 000 to €200 000, TD-GC/FID-MS €130 000 to €150 000), so significantly lower than the estimation proposed so far. The analysis costs are estimated to be between €3500 to €5000 per sample; the lower end of the range representing the case scenario where at least five samples are analysed on the same day.

Acknowledgments

This paper is written as part of the European Metrology Research Programme (EMPIR) project ‘Metrology for hydrogen vehicles’, and the authors would like to acknowledge the funding of this Programme by EURAMET (the European Association of National Metrology Institutes) and the European Commission.

ORCID iDs

K Arrhenius  <https://orcid.org/0000-0002-4037-3106>

Oliver Bükér  <https://orcid.org/0000-0001-5118-0150>

References

- [1] UK H2 Mobility 2013 UK H2 mobility: phase 1 results *Technical Report* (April)
- [2] European Climate Foundation (ECF) 2015 Fuelling france *Technical Report* (Cambridge: Cambridge Economics)
- [3] Hayter D 2014 Global H2Mobility initiatives—what they mean for FCEV introduction *Technical Report* (UK: H2Mobility)
- [4] Zhang X, Galindo H, Garces H, Baker P, Wang X, Pasaogullari U, Suib S and Molter T 2010 Influence of formic acid impurity on proton exchange membrane fuel cell performance *J. Electrochem. Soc.* **157** B409–B414
- [5] Molter T 2012 Final report—effects of impurities on fuel cell performance and durability (August 2012)
- [6] Jacques P-A, Ihonen J and Koski P 2014 Review on the impact of impurities on PEMFC and analytical methods for hydrogen QA *Technical Report* (Hydrogen Contaminant Risk Assessment (HyCoRA) Grant agreement no: 621223)
- [7] Bonnet C *et al* 2010 PEM fuel cell Pt anode inhibition by carbon monoxide: non-uniform behaviour of the cell caused by the finite hydrogen excess *Chem. Eng. Sci.* **65** 3050–8
- [8] ISO 14687:2019 2019 Hydrogen fuel quality—product specification (International Organization for Standardization)
- [9] ISO 17124:2019 2019 Hydrogen fuel—product specification and quality assurance—proton exchange membrane (PEM) fuel cell applications for road vehicles (International Organization for Standardization)
- [10] Haloua F *et al* 2016–2019 Literature review of impurity analysis methods for the compounds mentioned in ISO 14687-2:2012 (<http://projects.lne.eu/jrp-hydrogen/>) EMPIR JRP 15NRM03 “Metrology for sustainable hydrogen energy applications”(Hydrogen) activity A2.1.1
- [11] Murugan A *et al* 2019 Measurement challenges for hydrogen vehicles *Int. J. Hydrogen Energy* **44** 19326–33
- [12] ISO 21087:2018 2018 Gas analysis—analytical methods for hydrogen fuel—proton exchange membrane (PEM) fuel

- cell applications for road vehicles (International Organization for Standardization)
- [13] Murugan A, Bacquart T and Brewer P 2016 Recent developments on quality assurance of fuel cell hydrogen (<https://www.bipm.org/ws/AllowedDocuments.jsp&ws=GAWG2016>)
- [14] Emerson Automation Solutions 2019 Finding and reducing the “hidden costs” in gas chromatograph installations *Technical Report* Emerson June 2019 White paper
- [15] MacMillan D H 2003 Elements of a typical laboratory budget *Lab. Med.* **34** 515–19
- [16] Carré M 2018 How to ensure H₂ quality without increasing H₂ analysis cost? (<http://projects.lne.eu/jrp-hydrogen/workshop/>)
- [17] Gozlan B et al 2017–2020 Literature review of existing analytical methods for hydrogen purity analysis a specified in ISO 14687 (<http://www.metrohyve.eu>)
- [18] ASTM D7653-10:2010 2010 Standard test method for determination of trace gaseous contaminants in hydrogen fuel by fourier transform infrared (FTIR) spectroscopy (West Conshohocken, PA: Standard, ASTM International)
- [19] ASTM D7941-14:2014 2014 Standard test method for hydrogen purity analysis using a continuous wave cavity ring-down spectroscopy analyzer (West Conshohocken, PA: Standard, ASTM International)
- [20] Meuzelaar H et al Trace level analysis of reactive ISO14687-2 impurities in hydrogen fuel using laser-based spectroscopic detection methods (in preparation)
- [21] Bacquart T et al 2018 Probability of occurrence of ISO 14687-2 contaminants in hydrogen: principles and examples from steam methane reforming and electrolysis (water and chlor-alkali) production processes model *Int. J. Hydrogen Energy* **43** 11872–83
- [22] Arrhenius K, Bacquart T and Murugan A 2017–2020 Review and selection of compounds for total measurements (halogenated, sulphur and hydrocarbons) (<http://www.metrohyve.eu>)
- [23] ISO 6142-1:2015 2015 Gas analysis—preparation of calibration gas mixtures—part 1: gravimetric method for class I Mixtures (International Organization for Standardization)
- [24] Arrhenius K and Fischer A 2016–2019 Speciation method based on gas chromatography for the measurement of separate hydrocarbons in hydrogen (<http://projects.lne.eu/jrp-hydrogen/>)
- [25] Arrhenius K, Fischer A and Engelbrektsson J 2017–2020 Development and validation of a method for performing measurement of hydrogen sulfide at the threshold levels specified in ISO14687 (<http://www.metrohyve.eu>)
- [26] Down R D and Lehr J H 2005 *Environmental Instrumentation and Analysis Handbook* (Hoboken, NJ: Wiley)
- [27] Magnusson B 2014 *The Fitness for Purpose of Analytical Methods: A Laboratory Guide to Method Validation and Related Topics* 2nd edn (Torino: Eurachem)
- [28] Gagliardi G and Loock H-P ed 2014 *Cavity-Enhanced Spectroscopy and Sensing* Springer Series in Optical Sciences (Heidelberg: Springer-Verlag)
- [29] Magnusson B, Näykki T, Hovind H and Krysell M 2012 *Handbook for Calculation of Measurement Uncertainty in Environmental Laboratories* (Taastrup: Nordtest)